



**KIESELMANN**  
FLUID PROCESS GROUP

## Operating instructions

- Translation of the original -

### Butterfly valves



# 1. List of contents

1.	List of contents .....	2
2.	Information for your safety.....	3
3.	Marking of security instructions in the operating manual .....	3
4.	Safety instructions .....	4
4.1	Field of application .....	4
4.2	General safety instructions .....	4
4.3	General notes .....	4
5.	Function.....	4
5.1	General functional description .....	4
5.2	Functional description for butterfly valves - manual operation .....	4
5.3	Functional description for butterfly valves - pneum. operation.....	4
5.4	Functional description for leakage-butterfly valves .....	4
6.	Installation informations.....	5
6.1	Installation instructions.....	5
6.2	Welding guidelines.....	5
7.	Maintenance.....	5
7.1	Maintenance .....	5
7.2	Cleaning.....	5
7.3	Dry running .....	5
8.	Control system - and interrogation system.....	6
8.1	Retrofitting for limit position feed-back.....	6
8.2	Conversion to pneumatic actuation.....	6
8.3	Position control and position indication.....	6
8.4	Control head .....	6
9.	Technical data .....	7
9.1	Butterfly valve / Intermediated flanged butterfly valve.....	7
9.2	Leakage - Butterfly valve .....	8
10.	Disassembly and assembly.....	9
10.1	Disassembly - Butterfly valve manual operation .....	9
10.2	Assembly .....	9
10.3	Disassembly - Butterfly valve pneum. operation.....	10
10.4	Assembly .....	10
11.	Manufacturing.....	11
12.	Valve types.....	12
12.1	Butterfly valves.....	12
12.2	Intermediated flanged butterfly valve .....	12
12.3	Leakage-butterfly valve .....	12
13.	Drawing .....	13
13.1	Butterfly valve .....	13
13.2	Intermediated flanged butterfly valve .....	14
13.3	Leakage-butterfly valve - Base valve Typ: LSV4365 .....	15
14.	Dimensions.....	16
14.1	Butterfly valve .....	16
14.2	Intermediated flanged butterfly valve .....	17
14.3	Leakage-butterfly valve .....	18
15.	Manufacturing.....	19
15.1	Structure of Article number .....	19
16.	Wearing parts list.....	20
16.1	Butterfly valve .....	20
16.2	Intermediated flanged butterfly valve .....	20
16.3	Leakage-Butterfly valve .....	21
17.	Declaration of incorporation .....	22

## 2. Information for your safety

We are pleased that you have decided for a high-class KIESELMANN product. With correct application and adequate maintenance, our products provide long time and reliable operation.



Before installation and initiation, please carefully read this instruction manual and the security advices contained in it. This guarantees reliable and safe operation of this product and your plant respectively. Please note that an incorrect application of the process components may lead to great material damages and personal injury.

**In case of damages caused by non observance of this instruction manual, incorrect initiation, handling or external interference, guarantee and warranty will lapse!**

Our products are produced, mounted and tested with high diligence. However, if there is still a reason for complaint, we will naturally try to give you entire satisfaction within the scope of our warranty. We will be at your disposal also after expiration of the warranty. In addition, you will also find all necessary instructions and spare part data for maintenance in this instruction manual. If you don't want to carry out the maintenance by yourself, our KIESELMANN service team will naturally be at your disposal.

## 3. Marking of security instructions in the operating manual

Hints are available in the chapter "safety instructions" or directly before the respective operation instruction. The hints are highlighted with a danger symbol and a signal word. Texts beside these symbols have to be read and adhered to by all means. Please continue with the text and with the handling at the valve only afterwards.

Symbol	Signal word	Meaning
	<b>DANGER</b>	Imminent danger which may cause severe personal injury or death.
	<b>ATTENTION</b>	Dangerous situation which may cause slight personal injury or material damages.
	<b>NOTE</b>	Marks application hints and other information which is particularly useful.

## 4. Safety instructions

### 4.1 Field of application

The Butterfly valve is used as a shut-off valve in the food and beverage industry, in pharmaceutical and chemical engineering, as well as in bio-engineering.



#### ATTENTION

- To avoid danger and damage, the fitting must be used in accordance with the safety instructions and technical data contained in the operating instructions.

### 4.2 General safety instructions



#### DANGER

- Dismantling the valve or valve assemblies from the plant can cause injuries from fluids or gases flowing out. Dismantle the valve or valve assembly only when the plant has been rendered pressure-less and free of liquid and gas.
- Under pneumatic actuation of the valve, Limbs can get crushed or cut if they are inserted in the passageway of the valve.  
In general, before assembly activities, disconnect the compressed air pipe from the drive.
- Liquids flowing through the leakage drain outlet are to be drained off without splashing into a discharge arrangement.  
Before starting the system, the entire pipeline system must be thoroughly cleaned



#### ATTENTION

- To avoid air leaking, only use pneumatic connection parts that have an O-ring seal facing the even surface.

### 4.3 General notes



#### NOTE

All data are in line with the current state of development. Subject to change as a result of technical progress.

## 5. Function

### 5.1 General functional description

Open or close the valve by turning the pneum. controlled rotary drive by 90°.

### 5.2 Functional description for butterfly valves - manual operation

When actuating a fitting manually, the respective switching position will be locked in place in the final position. The manually operated lever is positioned at an angle of 90° in transverse direction to the conduit axis in closed position; this lever is positioned in the direction of the conduit axis in open position.

### 5.3 Functional description for butterfly valves - pneum. operation

The valve opens and closes by way of a pneum. multiturn actuator with a rotary movement of 90°.

- air open - spring close (lö-fs)
  - ▶ pneum. ENGAGED ⇒ opens the valve
  - ▶ not pneum. ENGAGED ⇒ spring force closes the valve
- spring open - air close (fö-ls)
  - ▶ pneum. ENGAGED ⇒ closes the valve
  - ▶ not pneum. ENGAGED ⇒ spring force opens the valve
- air open - air close (lö-ls)
  - ▶ pneum. ENGAGED ⇒ the valve opens or closes according to control

### 5.4 Functional description for leakage-butterfly valves

When closed, the butterfly valve with a tandem seal ensures that different media remain separated without leaking. The medium flows depressurised through the leakage drain ring-groove and out the leakage drain outlet. For hygienically demanding products, we recommend cleaning the leakage drain area. (Cleaning connection R1/4").

## 6. Installation informations

### 6.1 Installation instructions

#### Fitting position

For valves without leakage outlet, the installation position is without importance.

Leakage - disk valves must always be installed vertically to ensure that outflow of leakage, or of cleaning medium, from the valve is such that no residue will remain inside the valve.

For valves which are to be welded in on both sides, a releasable connection has to be fitted into the pipework to allow dismounting (maintenance).



#### NOTE

#### Fluid leak at the leakage drain (L) - only for Leakage butterfly valves

- small amount of liquid ⇒ part of the design when the valve is opening and closing
- Liquid continuously leaking when valve is closed ⇒ seal is damaged (replace the seal)
- Cleaning agent ⇒ cleaning the leakage drain area

### 6.2 Welding guidelines

Sealing elements integrated in weld components must generally be removed prior to welding.

To prevent damage, welding should be undertaken by certified personnel (EN287). Use the TIG (Tungsten Inert Gas) welding process.



#### NOTE

Impurities can cause damage to the seals and seals area. Clean inside areas prior to assembly.

## 7. Maintenance

### 7.1 Maintenance

The maintenance intervals depend on the operating conditions "temperature, temperature-intervals, medium, cleaning medium, pressure and opening frequency". It is recommended to change the leakage butterfly valve-seal annually. The maintenance intervals, however, depend on the condition of the seals and are to be fixed by the user.



#### NOTE

		<u>Lubricant recommendation</u>
EPDM; Viton; K-flex	⇒	Klüber Paraliq GTE*
NBR; HNBR; Silikon	⇒	Klüber Paraliq GB 363*
Thread	⇒	Teflon grease Interflon*

\*) It is only permitted to use approved lubricants, if the respective fitting is used for the production of food or drink. Please observe the relevant safety data sheets of the manufacturers of lubricants.

### 7.2 Cleaning

For best cleaning results, keep the valve open during cleaning to completely rinse the gasket and the valve head.

### 7.3 Dry running

The butterfly valves should not be operated in dry-run mode for lengthy periods wherever this can be avoided, as this will lead to increased wear.

## 8. Control system - and interrogation system

### 8.1 Retrofitting for limit position feed-back

By replacing the hand lever (1) and the catch disc (3) the valve can be retrofitted for limit position feed-back (proximity switch).

### 8.2 Conversion to pneumatic actuation

By a simple retrofitting operation the valve can be converted to pneumatic actuation. The rotary actuator for this purpose is supplied complete with fitting device. The following actuators are available, depending on the desired actuating function:

#### ➤ Butterfly valve / Intermediated flanged butterfly valve

Nominal diameter DN						Actuator	Conversion kit Art.-No.	Function
15-20 -	25-40 1"-1½"	50 2"	65-100 2½"-4"	125 -	150 -			
X	X	-	-	-	-	PDA 90/75	4500.050.075-022 -----	- air open - spring close - air close - spring open - air open - spring close
-	X	X	-	-	-	PDA 90/100	4500.050.100-022 4400.050.100-022	- air open - spring close - air close - spring open - air open - spring close
-	-	-	X	-	-	PDA 90/100	4500.100.100-022 4400.100.100-022	- air open - spring close - air close - spring open - air open - spring close
-	-	-	-	X	-	PDA 90/125	4500.125.125-022 4400.125.125-022	- air open - spring close - air close - spring open - air open - spring close
-	-	-	-	-	X	PDA 90/125	4500.150.125-022 4400.150.125-022	- air open - spring close - air close - spring open - air open - spring close

#### ➤ Leakage - butterfly valve

Nominal diameter DN				Actuator	Conversion kit Art.-No.	Function
50 - 80 2" - 3"	100 4"	125 -	150 -			
X	-	-	-	PDA 90/100	4200.080.100-022 4100.080.100-022	- air open- spring close - air close - spring open - air open - spring close
-	X	-	-	PDA 90/125	4800.100.125-022 4700.100.125-022	- air open- spring close - air close - spring open - air open - spring close
-	-	X	-	PDA 90/125	4200.100.125-022 -----	- air open- spring close - air close - spring open - air open - spring close

### 8.3 Position control and position indication

The actuator is equipped with a proximity switch holding device and a position indication. When inductive proximity initiators M 12x1 are installed, the current "Open" or "Shut" position can be interrogated. By screwing the proximity initiator to the limit position the required switching gap for the signal transmission is established. When the valve is closed the position indication is oriented vertically to the direction of valve passage. When the valve is open it is oriented parallel to the valve passage.

### 8.4 Control head

Optionally, modular valve control systems can be installed to the actuator for reading and actuating valve positions. The standard version is a closed system with twofold limit position messaging (standard), with SPS, Interbus or ASI bus switch-on electronics, and integrated 3/2-way solenoid valves. For tough operating conditions we recommend employing a stainless steel hood.

## 9. Technical data

### 9.1 Butterfly valve / Intermediated flanged butterfly valve

<b>Valve size:</b>	DIN: DN 15 - DN 150 INCH: DN 1" - DN 4"									
<b>Connections:</b>	<ul style="list-style-type: none"> <li>• Welding flange</li> <li>• Flange PN10</li> <li>• Male part DIN11851</li> <li>• Liner/nut DIN11851</li> <li>• Clamp coupling DIN32676</li> <li>• Male part RJT (Special design)</li> </ul>									
<b>Temperature range:</b>	<ul style="list-style-type: none"> <li>• Ambient temperature: +4° to +45°C</li> <li>• Product temperature: +0° to +95°C medium-dependent</li> <li>• Sterilization temperature:               <table border="0" style="margin-left: 20px;"> <tr> <td>EPDM</td> <td>+140°C (SIP 30 min)</td> </tr> <tr> <td>HNBR</td> <td>+130°C (SIP 30 min)</td> </tr> <tr> <td>Silicone</td> <td>+110°C (SIP 30 min)</td> </tr> <tr> <td>Viton</td> <td>+90°C (SIP 30 min)</td> </tr> </table> </li> </ul>		EPDM	+140°C (SIP 30 min)	HNBR	+130°C (SIP 30 min)	Silicone	+110°C (SIP 30 min)	Viton	+90°C (SIP 30 min)
EPDM	+140°C (SIP 30 min)									
HNBR	+130°C (SIP 30 min)									
Silicone	+110°C (SIP 30 min)									
Viton	+90°C (SIP 30 min)									
<b>Operating pressure:</b>	<b>Working pressure:</b> <ul style="list-style-type: none"> <li>• DN 15 - DN 65 / DN 1" - DN 2½" = 16 bar *</li> <li>• DN 80 - DN 100 / DN 3" - DN 4" = 10 bar</li> <li>• DN 125 - DN 150 = 6 bar</li> </ul> <p style="font-size: small; margin-left: 20px;">* Valves with flange coupling PN10 may be used only with a working pressure up to 10 bar.</p> <b>Cleaning pressure:</b> <ul style="list-style-type: none"> <li>• max. 3 bar</li> </ul>									
<b>Vacuum:</b>	1,5 - 10 <sup>-6</sup> mbar x L <sub>S</sub> (test pressure 0,5mbar)									
<b>Control air:</b> <i>(only pneum. operation valves)</i>	<b>Control air pressure:</b>	<b>Quality of control air:</b>								
	<ul style="list-style-type: none"> <li>• 5,5 - 8,0 bar</li> </ul>	<ul style="list-style-type: none"> <li>• ISO 8573-1 : 2001 quality class 3</li> </ul>								
<b>Material:</b> <i>in product contact</i>	Stainless steel:	1.4301 / AISI304 1.4307 / AISI304L 1.4404 / AISI316L								
	Surfaces:	Ra < 0,8µm, e-polished								
	Material of seals:	EPDM (FDA) HNBR (FDA) Silicone (FDA) Viton (FDA)								





## 10. Disassembly and assembly

### 10.1 Disassembly - Butterfly valve manual operation

#### ➤ Butterfly valve

see Fig. 2 /page 13

- Unscrew the screw (H1).
- Remove the hand lever (H) and the catch disc (H2).
- Unscrew the screw joints (4) - (5).
- Remove the housing flange (1).
- Position the flap (2) in "open" position toward the seal (3).
- Deform the seal (2) manually to oval shape toward center of flap (2).
- Take the flap (2) at first with the short shaft end and then with the long shaft end out from the boreholes of the seal (3).

#### ➤ Intermediated flanged butterfly valve

see Fig. 3 /page 14

- Unscrew the screw joints (5) - (7).
- Remove the flange (8) and the seals (9).
- Unscrew the screw (H1).
- Take off the hand lever (H) and the catch disc (H2).
- Unscrew the screw joints (4) - (5) and remove the housing flange (1).
- Position the flap (2) in "open" position toward the seal (3).
- Deform the seal (2) manually to oval shape toward center of flap (2).
- Take the flap (2) at first with the short shaft end and then with the long shaft end out from the boreholes of the seal (3).

#### ➤ Leakage - butterfly valve

see Fig. 4 /page 15

- Dismount the leakage drain.
- Unscrew the screw (H1).
- Remove the hand lever (H) and the catch disc (H2).
- Unscrew the screws (7) and remove the disc (6).
- Remove the housing lower part (1b).
- Develop the seal (3) with the flap (2) out off the upper part (1a).
- Position the flap (2) in "open" position toward the seal (3).
- Deform the seal (2) manually to oval shape toward center of flap (2).
- Take the flap (2) at first with the short shaft end and then with the long shaft end out from the boreholes of the seal (3).

### 10.2 Assembly

- Thoroughly clean and slightly lubricate mounting areas and running surfaces.
- Assemble in reverse order.



#### NOTE

- Grease the two shafts of the flap (2) before inserting it into the seal (3) using a grease that is suitable for foods.
- When mounting the hand lever (H), be sure the lever orientation is matched up with the position slot at the square shaft. In this way the correct indication of the valve position by the hand lever (H) is ensured.

### 10.3 Disassembly - Butterfly valve pneum. operation



#### NOTE

Unscrew and remove control air and electrical lines, complete proximity switch mounting or control head.

#### ➤ Butterfly valve

see Fig. 2 /page 13

- Unscrew the screw (A4) and remove the actuator (A) with the square boss (A1).
- Unscrew the screw joints (4) and (5) and remove the housing flange (1).
- Remove the seal (3) and the flap (2).
- Deform the seal (2) manually to oval shape toward center of flap (2).
- Take the flap (2) at first with the short shaft end and then with the long shaft end out from the boreholes of the seal (3).

#### ➤ Intermediated flanged butterfly valve

see Fig. 3 /page 14

- Unscrew the screw joints (5) - (7).
- Remove the flange (8) and the seals (9).
- Unscrew the screw (A4) and remove the actuator (A) with the square boss (A1).
- Unscrew the screw joints (4) - (5) and remove the housing flange (1).
- Deform the seal (2) manually to oval shape toward center of flap (2).
- Take the flap (2) at first with the short shaft end and then with the long shaft end out from the boreholes of the seal (3).

#### ➤ Leakage - butterfly valve

see Fig. 4 /page 15

- Dismount the leakage drain.
- Unscrew the screw joints (4) - (5).
- Dismount the valve from the flange joint.
- Unscrew the screw (A3) and remove the actuator (A) with the square boss (A1).
- Unscrew the screw (A4) and remove the holding flange (A2).
- Unscrew the screws (7) and remove the disc (6).
- Remove the housing lower part (1b).
- Develop the seal (3) with the flap (2) out of the upper part (1a).
- Deform the seal (2) manually to oval shape toward center of flap (2).
- Take the flap (2) at first with the short shaft end and then with the long shaft end out from the boreholes of the seal (3).

### 10.4 Assembly

- Thoroughly clean and slightly lubricate mounting areas and running surfaces.
- Assemble in reverse order.



#### NOTE

- Grease the two shafts of the flap (2) before inserting it into the seal (3) using a grease that is suitable for foods.
- Close flap (spring closing position) before assembling the actuator (A). Do not install the actuator when set to pneumatic actuation (spring closing condition). The position indicator is oriented vertically to valve passage direction - valve position "shut".

# 11. Manufacturing

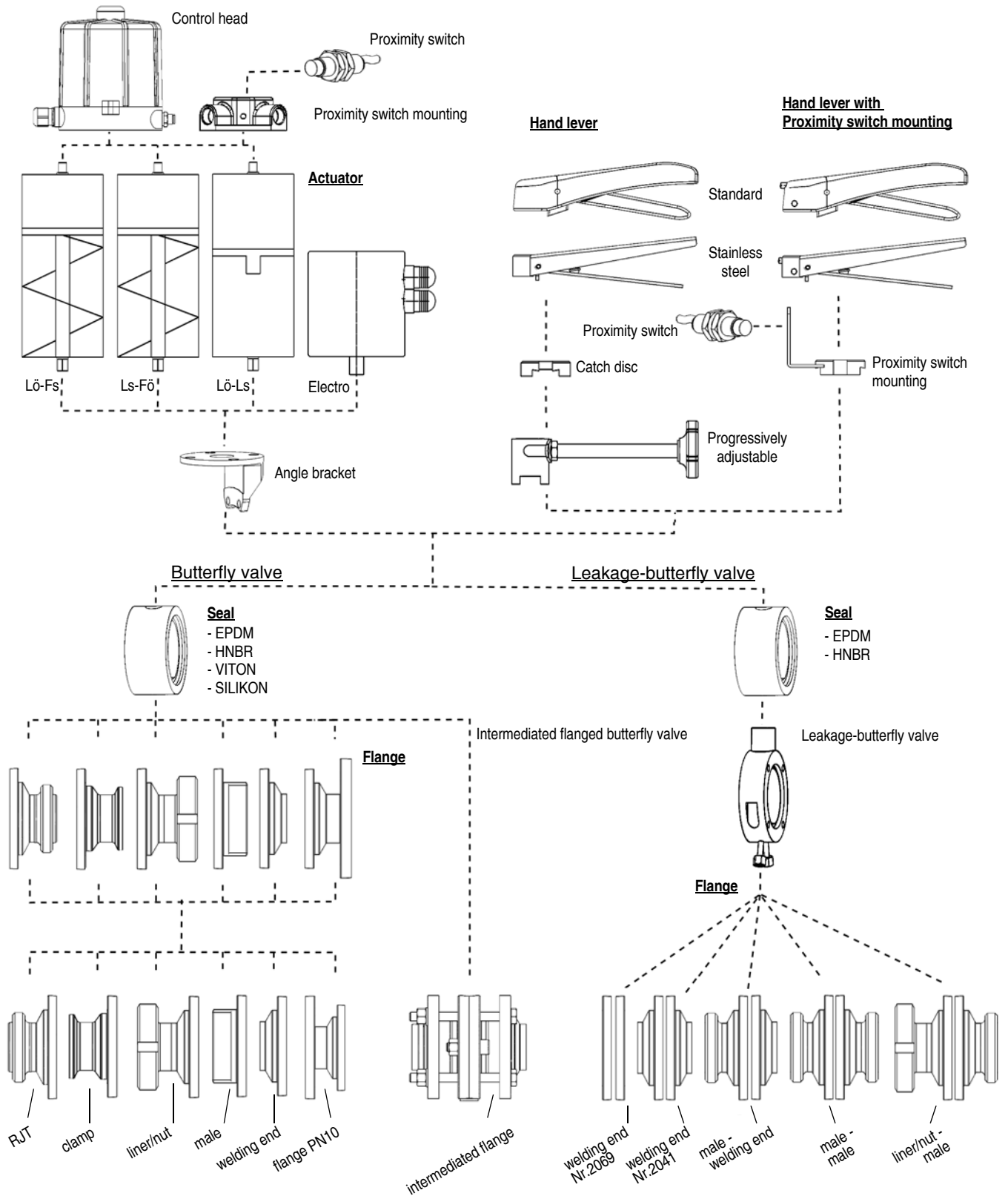











Fig. 1

## 12. Valve types







### 12.1 Butterfly valves

			manual	pneumatic	
				lö-fs	ls-lö
	<b>S - S</b>	DIN	4301	4501	4401
		INCH	4351	4551	4451
	<b>G - S</b>	DIN	4302	4502	4402
		INCH	4352	4552	4452
	<b>G - G</b>	DIN	4303	4503	4403
		INCH	4353	4553	4453
	<b>K/M - G</b>	DIN	4304	4504	4404
		INCH	4354	4554	4454
	<b>K/M - S</b>	DIN	4305	4505	4405
		INCH	4355	4555	4455
	<b>FI (PN10) - G</b>	DIN	4307	4507	4407
	<b>FI - FI (PN10)</b>				
	<b>G (RJT) - S</b>	INCH	4352 (RJT)	4552 (RJT)	4452 (RJT)
	<b>G - G (RJT)</b>	INCH	4353 (RJT)	4553 (RJT)	4453 (RJT)
	<b>CI - CI</b>	DIN	4346	4546	4446
		Zoll	4347	4547	4447

### 12.2 Intermediated flanged butterfly valve

			manual	pneumatic	
				lö-fs	ls-lö
	<b>S - S</b>	DIN	4310	4510	4410
		INCH	4358	4558	4458

### 12.3 Leakage-butterfly valve

			manual	pneumatic	
				lö-fs	ls-lö
	<b>Basis</b>	DIN/ INCH	4365	4865	4765
	<b>S - S</b>	DIN/ INCH	4366	4866	4766
	<b>S - S</b>	DIN/ INCH	4367	4867	4767
	<b>G - S</b>	DIN/ INCH	4368	4868	4768
	<b>G - G</b>	DIN/ INCH	4369	4869	4769
	<b>K/M - G</b>	DIN/ INCH	4370	4870	4770

S = Welding  
 G = Male  
 K/M = Liner/nut  
 FI = Flange  
 CI = Clamp  
 RJT = Male (RJT)  
 lö = air open  
 ls = air close  
 fö = spring open  
 fs = spring close

# 13. Drawing

## 13.1 Butterfly valve

- 1) Housing flange with:
  - a) Welding end
  - b) Male part
  - c) Liner/nut connection
  - d) Flange connection PN10
  - e) Male part (RJT)
  - f) Clamp connection

- 2) Flap
- 3) Seal
- 4) Screw
- 5) Nut
- 6) Cap

- A) Actuator
- A1) Square boss
- A2) Angle bracket
- A3) Screw
- A4) Screw

- H) Hand lever
- H1) Saucer-head screw
- H2) Catch disc

- LA) Compressed-air supply
- S) Control head

- R) Proximity witch mounting
- R1) Dog
- R2) Position indication
- R3) O-Ring
- R4) Screw
- R5) Proximity switch receiver
- R6) Cap
- R7) Screw

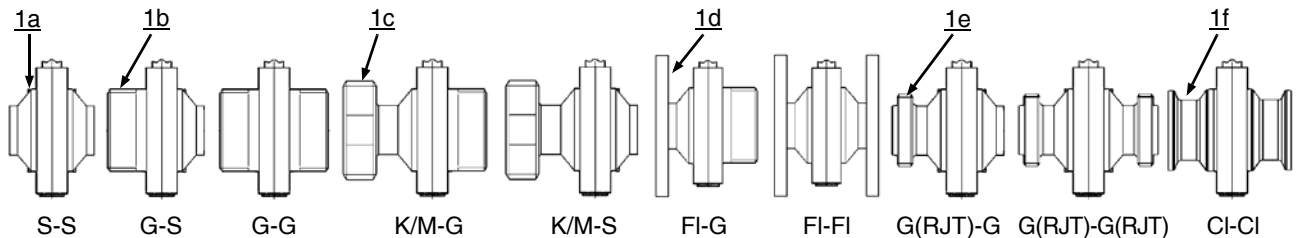
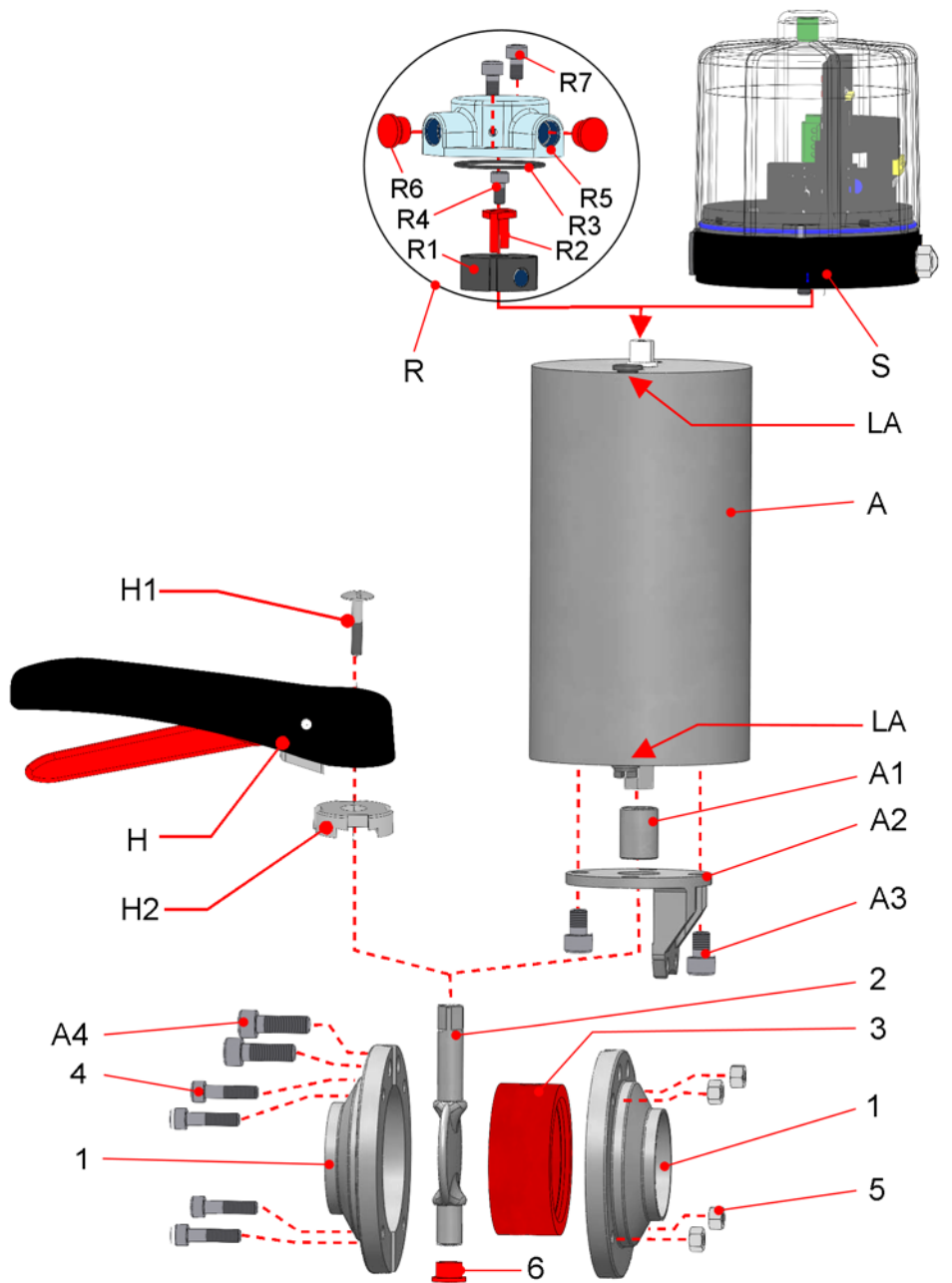

Fig. 2

### 13.2 Intermediated flanged butterfly valve

- 1) Housing flange
- 2) Flap
- 3) Seal
- 4) Screw
- 5) Nut
- 6) Cap
- 7) Screw
- 8) Flange
- 9) Seal
- 10) Disc

- A) Actuator
- A1) Square boss
- A2) Angle bracket
- A3) Screw
- A4) Screw

- H) Hand lever
- H1) Saucer-head screw
- H2) Catch disc

- LA) Compressed-air supply
- S) Control head

- R) Proximity witch mounting
- R1) Dog
- R2) Position indication
- R3) O-Ring
- R4) Screw
- R5) Proximity switch receiver
- R6) Cap
- R7) Screw

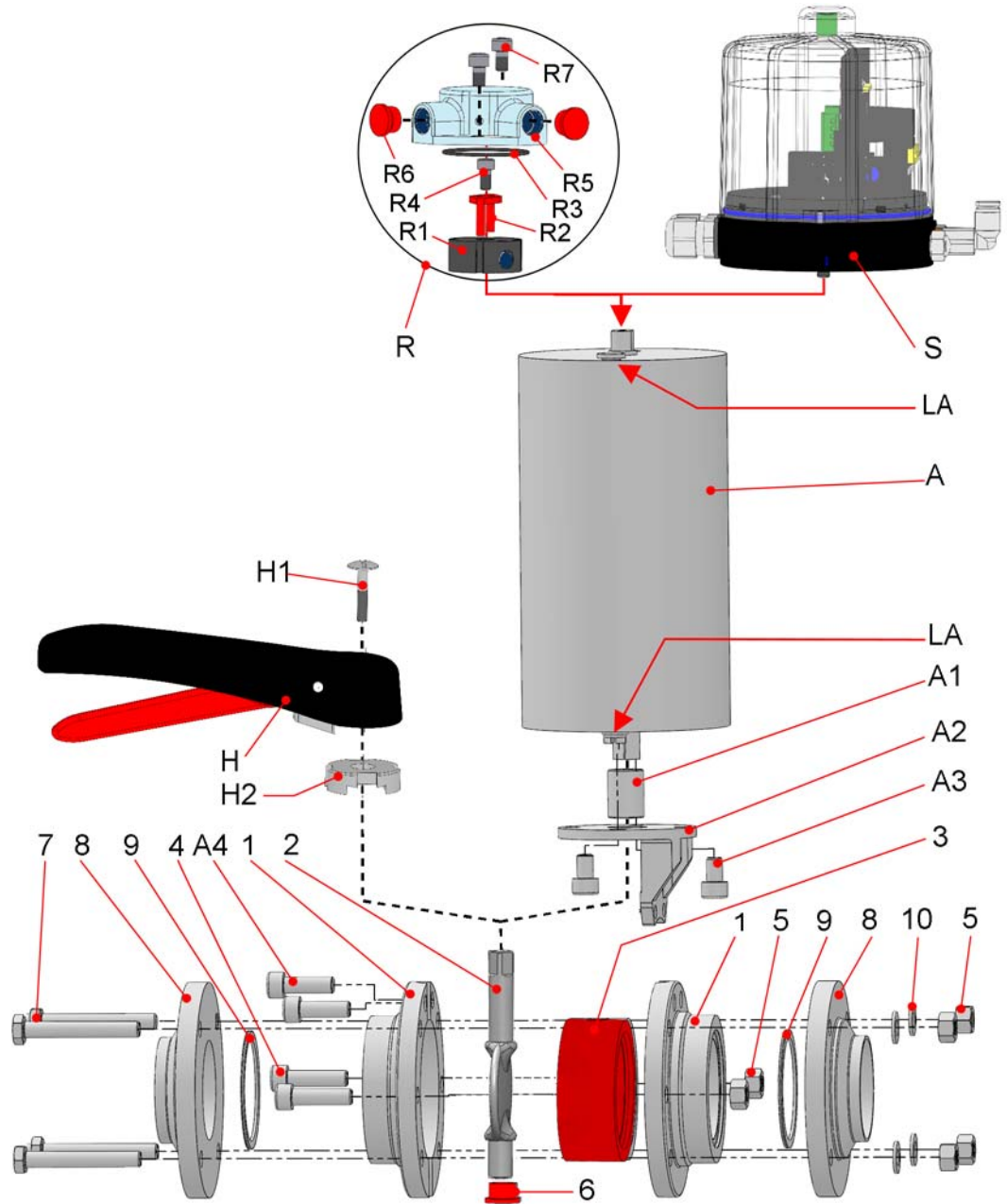

Fig. 3

### 13.3 Leakage-butterfly valve - Base valve Typ: LSV4365

- 1) a) Housing upper part  
b) Housing lower part
- 2) Flap
- 3) Seal
- 4) Screw
- 5) Nut
- 6) Disc
- 7) Screw
- 8) Flange with  
a) Welding end (2069)  
b) Welding end (2041)  
c) Male part  
d) Liner/nut-connection
- 9) Plain bearing

- A) Actuator
- A1) Square boss
- A2) Holding flange
- A3) Screws
- A4) Screws

- H) Hand lever
- H1) Saucer-head screw
- H2) Catch disc
- H3) Screws
- H4) Straight pin

- L) Leakage drain
- L1) O-Ring
- LA) Compressed-air supply
- S) Control head

- R) Proximity witch mounting
- R1) Dog
- R2) Position indication
- R3) O-Ring
- R4) Screw
- R5) Proximity switch receiver
- R6) Cap
- R7) Screw

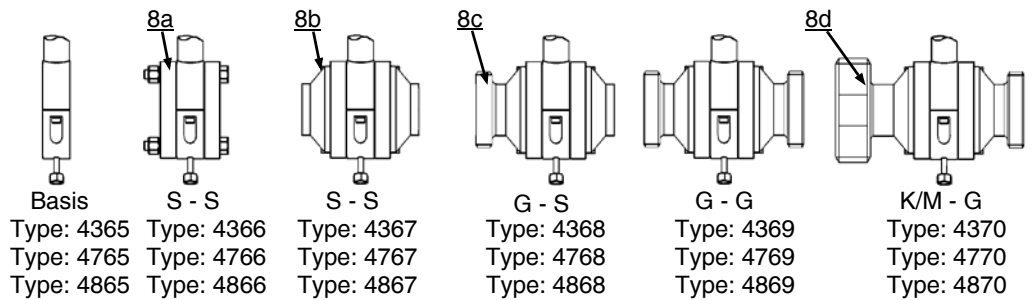
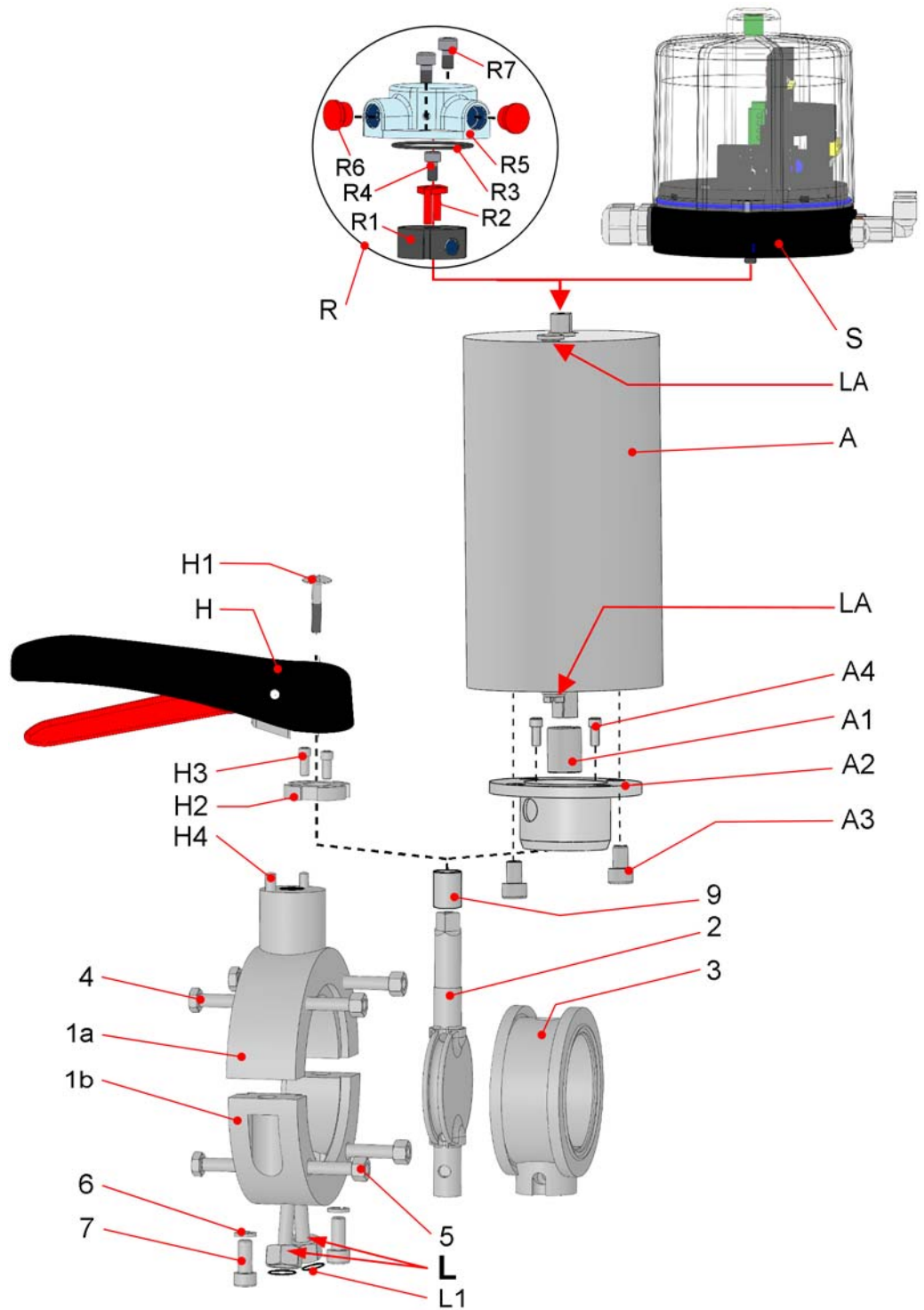

Fig. 4

## 14. Dimensions

### 14.1 Butterfly valve

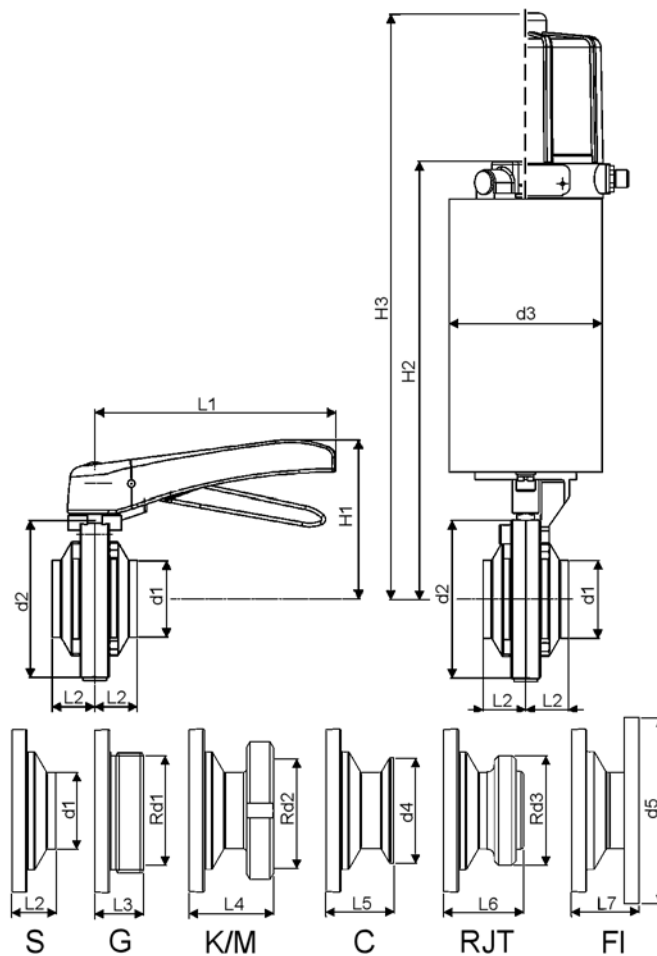

Fig. 5

DN / OD	d1	d2	d3	d4	d5	L1	L2	L3	L4	L5	L6	L7	H1	H2	H3	Rd1/Rd2	Rd3
15 (ø16)	ø19x1,5	ø62	ø76	ø34	-	100	24	34	41	34	-	-	78	232	333	Rd34x1/8	-
20 (ø20)	ø23x1,5	ø72	ø76	ø34	-	100	24	34	42	34	-	-	83	237	338	Rd44x1/6	-
25 (ø26)	ø29x1,5	ø80	ø104	ø50,5	ø115	165	27	34	49	34	-	66	95	285	386	Rd52x1/6	-
32 (ø32)	ø35x1,5	ø86	ø104	ø50,5	ø140	165	27	34	52	34	-	66	98	288	389	Rd58x1/6	-
40 (ø38)	ø41x1,5	ø92	ø104	ø50,5	ø150	165	27	34	53	34	-	60	101	291	392	Rd65x1/6	-
50 (ø50)	ø53x1,5	ø108	ø104	ø64	ø165	165	29	36	57	36	-	65	109	300	401	Rd78x1/6	-
65 (ø66)	ø70x2	ø130	ø104	ø91	ø185	165	30	38	62	38	-	73	121	311	412	Rd95x1/6	-
80 (ø81)	ø85x2	ø146	ø104	ø106	ø200	165	36	44	73	44	-	70	129	319	420	Rd110x1/4	-
100 (ø100)	ø104x2	ø166	ø104	ø119	ø220	165	34	44	78	44	-	77	139	329	430	Rd130x1/4	-
125 (ø125)	ø129x2	ø205	ø129	-	ø250	285	43	55	77	-	-	82	181	388	489	Rd160x1/4	-
150 (ø150)	ø154x2	ø240	ø129	-	ø285	285	52	65	89	-	-	91	199	407	508	Rd190x1/4	-
1" (ø22,9)	ø25,4x1,25	ø80	ø104	ø50,5	-	165	27	34	49	34	53	-	95	285	386	Rd52x1/6	Rd45,7x1/8
1½ (ø35,1)	ø38,1x1,5	ø92	ø104	ø50,5	-	165	27	34	53	34	53	-	101	291	392	Rd65x1/6	Rd58,4x1/8
2 (ø47,8)	ø50,8x1,5	ø108	ø104	ø64	-	165	29	36	57	29	55	-	109	300	401	Rd78x1/6	Rd72,7x1/6
2½ (ø60,5)	ø63,5x1,5	ø130	ø104	ø77,5	-	165	30	38	62	38	56	-	121	311	412	Rd95x1/6	Rd85,4x1/6
3 (ø72,1)	ø76,1x2	ø146	ø104	ø91	-	165	36	44	73	44	62	-	129	319	420	Rd110x1/4	Rd98,1x1/6
4 (ø97,6)	ø101,6x2	ø166	ø104	ø119	-	165	34	44	78	44	60	-	139	329	430	Rd130x1/4	Rd123,8x1/6





## 14.2 Intermediated flanged butterfly valve

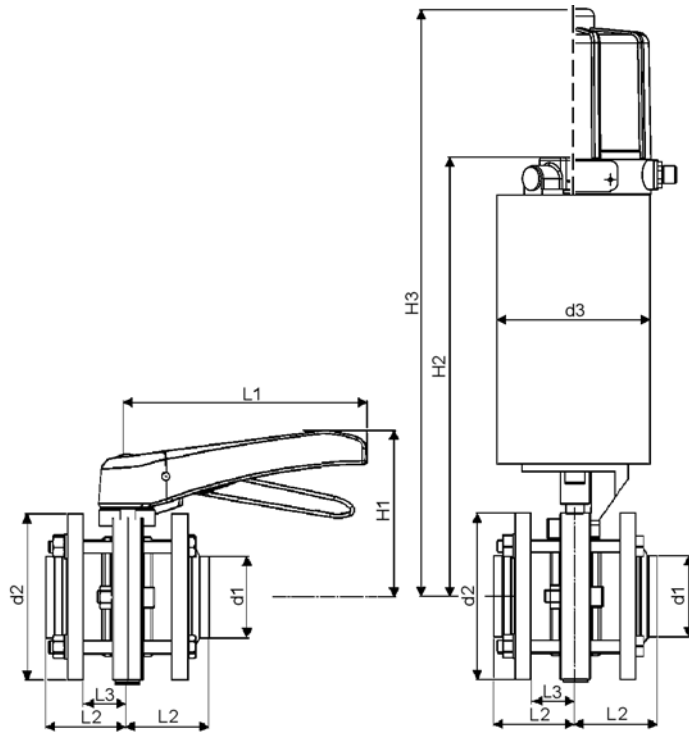
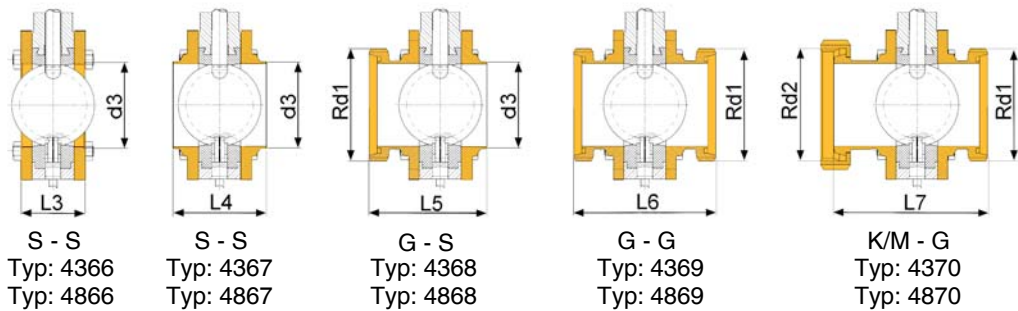
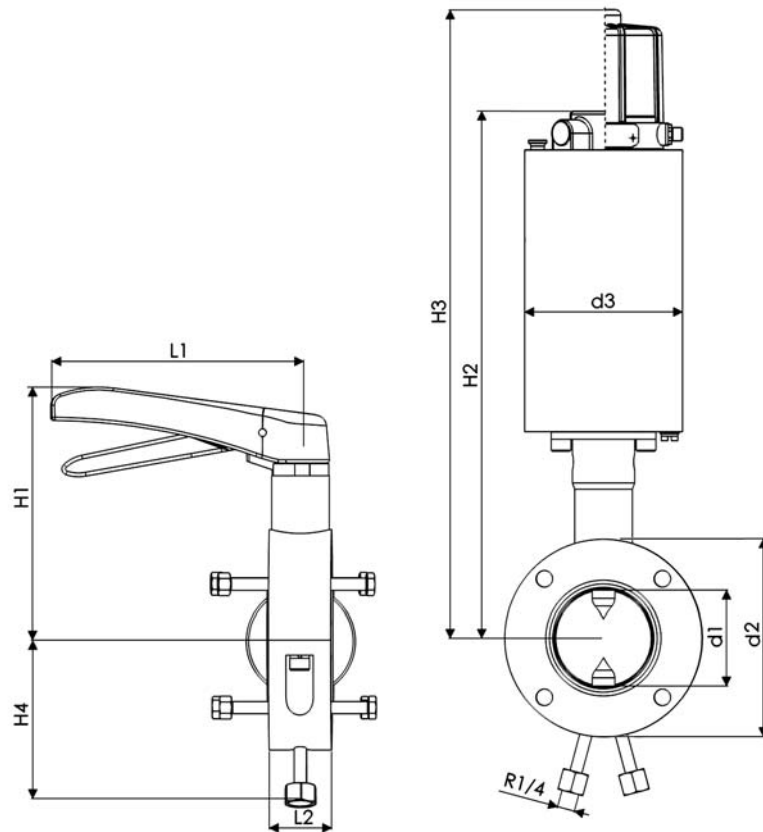

Fig. 6

DN / OD	d1	d2	d3	L1	L2	L3	H1	H2	H3
15 (ø16)	ø19x1,5	ø62	ø76	100	53	29	78	232	333
20 (ø20)	ø23x1,5	ø72	ø76	100	53	29	83	237	338
25 (ø26)	ø29x1,5	ø80	ø104	165	51	27	95	285	386
32 (ø32)	ø35x1,5	ø86	ø104	165	51	27	98	288	389
40 (ø38)	ø41x1,5	ø92	ø104	165	51	27	101	291	392
50 (ø50)	ø53x1,5	ø108	ø104	165	53	29	109	300	401
65 (ø66)	ø70x2	ø130	ø104	165	54	30	121	311	412
80 (ø81)	ø85x2	ø146	ø104	165	60	36	129	319	420
100 (ø100)	ø104x2	ø166	ø104	165	58	34	139	329	430
125 (ø125)	ø129x2	ø205	ø129	285	66	43	181	388	489
150 (ø150)	ø154x2	ø240	ø129	285	75	52	199	407	508
1" (ø22,9)	ø25,4x1,25	ø80	ø104	165	51	27	95	285	386
1½ (ø35,1)	ø38,1x1,5	ø82	ø104	165	51	27	101	291	392
2 (ø47,8)	ø50,8x1,5	ø108	ø104	165	53	29	109	300	401
2½ (ø60,5)	ø63,5x1,5	ø130	ø104	165	54	30	121	311	412
3 (ø72,1)	ø76,1x2	ø146	ø104	165	60	36	129	319	420
4 (ø97,6)	ø101,6x2	ø166	ø104	165	58	34	139	329	430

### 14.3 Leakage-butterfly valve



DN / OD	d1	d2	d3	L1	L2	L3	L4	L5	L6	L7	H1	H2	H3	H4	Rd1/Rd2
50 (ø50)	ø53x1,5	ø110	ø104	165	38	68	86	109	156	149	148	338	440	84	Rd78x1/6
65 (ø66)	ø70x2	ø130	ø104	165	38	68	86	111	166	158	158	349	451	94	Rd95x1/6
80 (ø81)	ø85x2	ø145	ø104	165	41	71	89	114	179	158	167	358	460	102	Rd110x1/4
100 (ø100)	ø104x2	ø165	ø129	180	41	71	89	118	197	187	178	407	509	112	Rd130x1/4
125 (ø125)	ø129x2	ø195	ø129	285	53	87	101	145	193	181	214	421	523	127	Rd160x1/4
150 (ø150)	ø154x2	ø240	ø154	285	34	-	150	-	-	-	-	406	507,5	71,4	-
2" (ø47,8)	ø50,8x1,5	ø110	ø104	165	38	68	86	-	-	-	148	338	440	84	Rd78x1/6
2½" (ø60,5)	ø63,5x1,5	ø130	ø104	165	38	68	86	-	-	-	158	349	451	94	Rd95x1/6
3" (ø72,1)	ø76,1x2	ø145	ø104	165	41	71	89	129	169	-	167	358	460	102	Rd110x1/4
4" (ø97,6)	ø101,6x2	ø165	ø104	180	41	87	101	-	-	-	178	407	509	112	Rd130x1/4

## 15. Manufacturing

### 15.1 Structure of Article number

**4502 050 130 - 041**

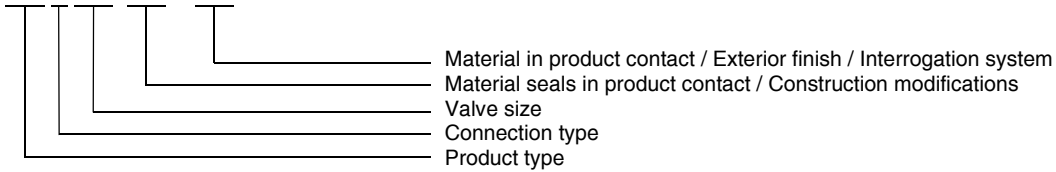

#### ➤ Product type

Typ 45xx - pneumatical Butterfly valve

#### ➤ Connection type

Male / Welding end

#### ➤ Valve size

DN = Nominal diameter

DIN	<b>010</b> = DN10	<b>015</b> = DN15	<b>020</b> = DN20	<b>025</b> = DN25	<b>032</b> = DN32	<b>040</b> = DN40	<b>050</b> = DN50
INCH	-	-	-	<b>026</b> = DN1	-	<b>038</b> = DN1½	<b>051</b> = DN2

DIN	<b>065</b> = DN65	<b>080</b> = DN80	<b>100</b> = DN100	<b>125</b> = DN125	<b>150</b> = DN150	-	-
INCH	<b>064</b> = DN2½	<b>076</b> = DN3	<b>101</b> = DN4	<b>126</b> = DN5	<b>151</b> = DN6	-	-

#### ➤ Material seal / Construction modifications

Material seals in product contact:

- EPDM
- HNBR
- Silicone
- Viton

Construction modifications: Kind of actuator

- Air / Air
- Air / Spring

#### ➤ Material in product contact / Exterior finish

<b>020</b> - 1.4301/1.4307 AISI304/307 - bright turned	<b>040</b> - 1.4301/1.4307 AISI304/307 - bright turned
<b>021</b> - 1.4301/1.4307 AISI304/307 - E-polished	<b>041</b> - 1.4301/1.4307 AISI304/307 - E-polished
<b>022</b> - 1.4301/1.4307 AISI304/307 - unpolished, glass-bead blasted	<b>042</b> - 1.4301/1.4307 AISI304/307 - unpolished, glass-bead blasted

#### ➤ Interrogation system

Article number	Control System or Interrogation System (A1, A2)
4xxx DN xxx - <b>041</b>	Valve without Control- or Interrogation System
4xxx DN xxx - <b>6xx</b>	Control head ASi-Bus for rotary valves
4xxx DN xxx - <b>K6xx</b>	Control head KI-Top ASi-Bus for rotary valves
4xxx DN xxx - <b>5xx</b>	Control head SPS for rotary valves
4xxx DN xxx - <b>K5xx</b>	Control head KI-Top SPS for rotary valves

DN - nominal diameter e.g. 4510 050 130-041

## 16. Wearing parts list

### 16.1 Butterfly valve

		Seal (3)			
DN		SILIKON	EPDM	HNBR	VITON
DIN	15	-	4328 015 000-054	4326 015 000-050	-
	20	-	4328 020 000-054	4326 020 000-050	-
	25	4326 025 000-052	4328 025 000-054	4326 025 000-050	4327 025 000-051
	32	4326 032 000-052	4328 032 000-054	4326 032 000-050	4327 032 000-051
	40	4326 040 000-052	4328 040 000-054	4326 040 000-050	4327 040 000-051
	50	4326 050 000-052	4328 050 000-054	4326 050 000-050	4327 050 000-051
	65	4326 065 000-052	4328 065 000-054	4326 065 000-050	4327 065 000-051
	80	4326 080 000-052	4328 080 000-054	4326 080 000-050	4327 080 000-051
	100	4326 100 000-052	4328 100 000-054	4326 100 000-050	4327 100 000-051
	125	4326 125 000-052	4328 125 000-054	4326 125 000-050	4327 125 000-051
	150	4326 150 000-052	4328 150 000-054	4326 150 000-050	4327 150 000-051
	INCH	1	4326 026 000-052	4328 026 000-054	4326 026 000-050
1½		4326 038 000-052	4328 038 000-054	4326 038 000-050	4327 038 000-051
2		4326 051 000-052	4328 051 000-054	4326 051 000-050	4327 051 000-051
2½		4326 064 000-052	4328 064 000-054	4326 064 000-050	4327 064 000-051
3		4326 076 076-052	4328 076 076-054	4326 076 076-050	4327 076 076-051
4		4326 101 000-052	4328 101 000-054	4326 101 000-050	4327 101 000-051

### 16.2 Intermediated flanged butterfly valve

		Seal (3)				Seal (9)
DN		SILIKON	EPDM	HNBR	VITON	k-flex
DIN	15	-	4328 015 000-054	4326 015 000-050	-	2353 021 016-114
	20	-	4328 020 000-054	4326 020 000-050	-	2353 028 020-114
	25	4326 025 000-052	4328 025 000-054	4326 025 000-050	4327 025 000-051	2353 035 026-114
	32	4326 032 000-052	4328 032 000-054	4326 032 000-050	4327 032 000-051	2353 041 032-114
	40	4326 040 000-052	4328 040 000-054	4326 040 000-050	4327 040 000-051	2353 047 038-114
	50	4326 050 000-052	4328 050 000-054	4326 050 000-050	4327 050 000-051	2353 059 050-114
	65	4326 065 000-052	4328 065 000-054	4326 065 000-050	4327 065 000-051	2353 076 066-114
	80	4326 080 000-052	4328 080 000-054	4326 080 000-050	4327 080 000-051	2353 090 081-114
	100	4326 100 000-052	4328 100 000-054	4326 100 000-050	4327 100 000-051	2353 109 100-114
	125	4326 125 000-052	4328 125 000-054	4326 125 000-050	4327 125 000-051	2353 136 125-114
	150	4326 150 000-052	4328 150 000-054	4326 150 000-050	4327 150 000-051	2353 161 150-114
	INCH	1	4326 026 000-052	4328 026 000-054	4326 026 000-050	4327 026 000-051
1½		4326 038 000-052	4328 038 000-054	4326 038 000-050	4327 038 000-051	2353 044 036-114
2		4326 051 000-052	4328 051 000-054	4326 051 000-050	4327 051 000-051	2353 057 049-114
2½		4326 064 000-052	4328 064 000-054	4326 064 000-050	4327 064 000-051	2353 071 061-114
3		4326 076 076-052	4328 076 076-054	4326 076 076-050	4327 076 076-051	2353 083 073-114
4		4326 101 000-052	4328 101 000-054	4326 101 000-050	4327 101 000-051	2353 107 099-114

### 16.3 Leakage-Butterfly valve

	DN	Seal (3)			Plain bearing (9)	Seal (L1)
		SILIKON	EPDM	HNBR	iglidur®	EPDM
<b>DIN</b>	<b>50</b>	4378 050 000-052	4377 050 000-054	4378 050 000-050	8050 012 010-060	2354 012 006-054
	<b>65</b>	4378 065 000-052	4377 065 000-054	4378 065 000-050	8050 012 010-060	II
	<b>80</b>	4378 080 000-052	4377 080 000-054	4378 080 000-050	8050 015 010-060	II
	<b>100</b>	4378 100 000-052	4377 100 000-054	4378 100 000-050	8050 015 010-060	II
	<b>125</b>	4378 125 000-052	4377 125 000-054	4378 125 000-050	8050 020 015-156	II
	<b>150</b>	-	-	-	-	
<b>INCH</b>	<b>2</b>	4378 050 000-052	4377 050 000-054	4378 050 000-050	8050 012 010-060	2354 012 006-054
	<b>2½</b>	4378 065 000-052	4377 065 000-054	4378 065 000-050	8050 012 010-060	II
	<b>3</b>	4378 076 000-052	4377 076 000-054	4378 076 000-050	8050 015 010-060	II
	<b>4</b>	4378 100 000-052	4377 100 000-054	4378 100 000-050	8050 015 010-060	II



## **Declaration of incorporation**

Translation of the original

*Manufacturer /* authorised representative:

KIESELMANN GmbH  
Paul-Kieselmann-Str. 4-10  
75438 Knittlingen  
Germany

Authorised representative,  
for compiling technical documents:

Achim Kauselmann  
KIESELMANN GmbH  
Paul-Kieselmann-Str. 4-10  
75438 Knittlingen  
Germany

### **Product name**

pneum. Lift actuators  
pneum. Rotary actuators  
Ball valves  
Butterfly valves  
Single seat valves  
Flow control valves  
Throttle valve  
Overflow valve  
Double seat valve  
Bellow valves  
Sampling valves  
Two way valves  
Tankdome fitting

### **Function**

Stroke movement  
Rotary movement  
Media cutoff  
Media cutoff  
Media cutoff  
Control of liquefied media  
Control of liquefied media  
Definition of fluid pressure  
Media separation  
Sampling of liquids  
Sampling of liquids  
Media cutoff  
Prevention of overpressure and vacuum, Tank cleaning

The manufacturer hereby states that the above product is considered as an incomplete machine in the sense defined in the Directive 2006/42/EC on Machinery. The above product is exclusively intended to be installed into a machine or an incomplete machine. The said product does not yet conform to all the relevant requirements defined in the Directive on Machinery referred to above for this reason.

The specific technical documents listed in Appendix VII, Part B, have been prepared. The Authorized Agent empowered to compile technical documents may submit the relevant documents if such a request has been properly justified.

Commissioning of an incomplete machine may only be carried out if it has been determined that the respective machine into which the incomplete machine is to be installed conforms to the regulations set out in the Directive on Machinery referred to above.

The above product conforms to the requirements of the directives and harmonized standards specified below:

- DIN EN ISO 12100 Safety of machinery

Knittlingen, 16. 07. 2012

**Klaus Dohle**  
General Director