



Design and applications

The SGK 1 - 3 flow meters are based on the variable area float principle. They consist of a combination of borosilicate glass measuring cone and float, with a flow scale specific to the process fluid and calibrated to customer requirements. The SGKs can optionally be equipped with a valve and can then be used for dosing small and minimum volumes of clear gases and liquids.

By installation of electrical limit value switches, which are adjustable throughout the entire measuring range, these devices can be used as detectors.

By installing a linear displacement sensor an output signal can be generated which is proportional to the height setting of the flow meter.

The devices are suitable for use on small furnace plants, in dosing systems and for monitoring small volumes in cooling processes.

You will find an exact explanation of the function principle and the measuring principle of variable area flow meters in our technical documents.

SGK 1 - 3



- **direct-reading scale**
- **simple and reliable**
- **short-tube design**
- **for process flow measurement of gases and liquids**
- **for measurement of small and minimum volumes**
- **calibrated scale specific to the process fluid**
- **optionally**
 - **proportioning valve**
 - **floating reed switch**
 - **inductive switch**
 - **4 ... 20 mA analogue output**
 - **explosion-proof design**





SGK 1 - 3

Short-tube VA flow meters

Type series

SGK-1	measures smallest air- and water volumes
SGK-2	measures medium small air- and water volumes
SGK-3	measures small air- and water volumes
...-MSK1	with limit value switch (Normally closed)
...-MSK12	with limit value switch (Normally open)
...-MSKW	with limit value switch (Change over)
...-RC ¹⁾	with inductive limit value switch ¹⁾
...-EM ²⁾	with 4 ... 20 mA / 0 ... 10 V analogue output

¹⁾ for volume flow less than 2 l/h H₂O resp. 80 l/h air i.N.)

²⁾ only SGK-2, other sizes on request

Technical data

Device body	
Connection	external-/internal thread to DIN EN ISO 228 T1, optionally tube grommet
Designs	A – Do, see table on page 3
Thermal endurance	80 °C with NBR gaskets 100 °C with FKM gaskets
Operating pressure	max. 10 bar, no pressure surges

Tempered measuring glass	
Scale	burnt-in scale
Length of scale SGK 1-2	approx. 150 mm
Length of scale SGK 3	approx. 220 mm
Accuracy class	VDE/VDI 3513 page 2 (08/2008)
Error limit (G)	1,6 %
Linear limit (qG)	50 %
Calibration	according to customer requirements

Materials

Bracket	aluminium, black anodized
Connections	standard: Anodized aluminium or PVC optionally: 1.4571, PVDF
Gaskets	standard: NBR (for aluminium devices) FKM (for 1.4571 devices) optionally: EPDM, Perlast [®] (FFKM)
Measuring glass	borosilicate glass
Float	aluminium anodized, PVC, 1.4571, optionally PP
Valve	1.4571

other materials on request

Dimensions

	G [inch]	shape	H [mm]	h [mm]	M	L [mm]	B [mm]	D [mm]	C [mm]
SGK-1	¼	A ₁ , A ₂ , A ₀	238	213	–	ca. 22,5	27,5	30	80 (only A ₁ , A ₂)
SGK-2	¼	A ₁ , A ₂ , A ₀	238	213	–	ca. 22,5	27,5	30	80 (only A ₁ , A ₂)
		B, B ₀ , C, C ₀	242	211	M5	ca. 22,5	27,5	30	80 (only B, C)
	¼ i	D ₀	246	209	M5	ca. 22,5	27,5	30	–
SGK-2-EM	¼	A ₁ , A ₂ , A ₀	238	213	–	ca. 17	33	60	85 (only A ₁ , A ₂)
SGK-3	½	A ₁ , A ₂ , A ₀	363	323	–	ca. 27	45	50	135 (only A ₁ , A ₂)
		B, B ₀ , C, C ₀	363	320	M8	ca. 27	45	50	135 (only B, C)
	½ i	D ₀	363	317	M8	ca. 27	45	50	–

see also dimensional drawing on next page

Design

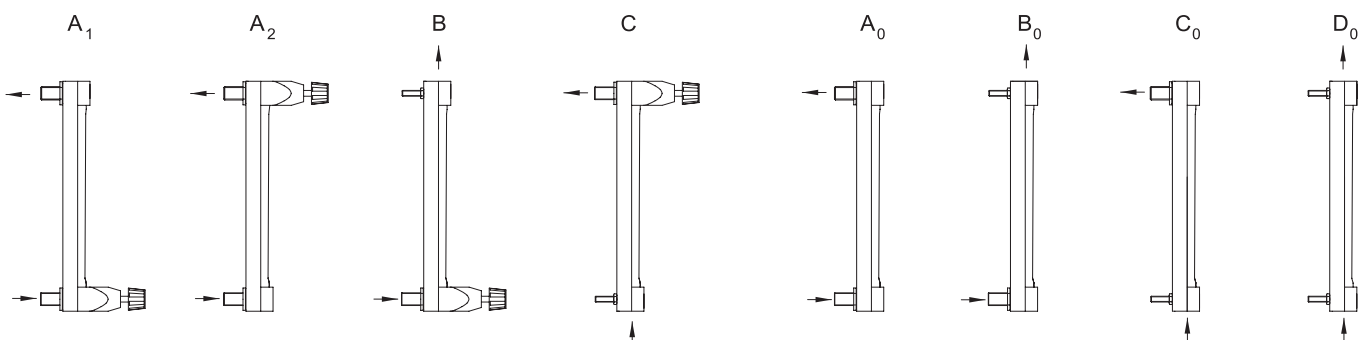

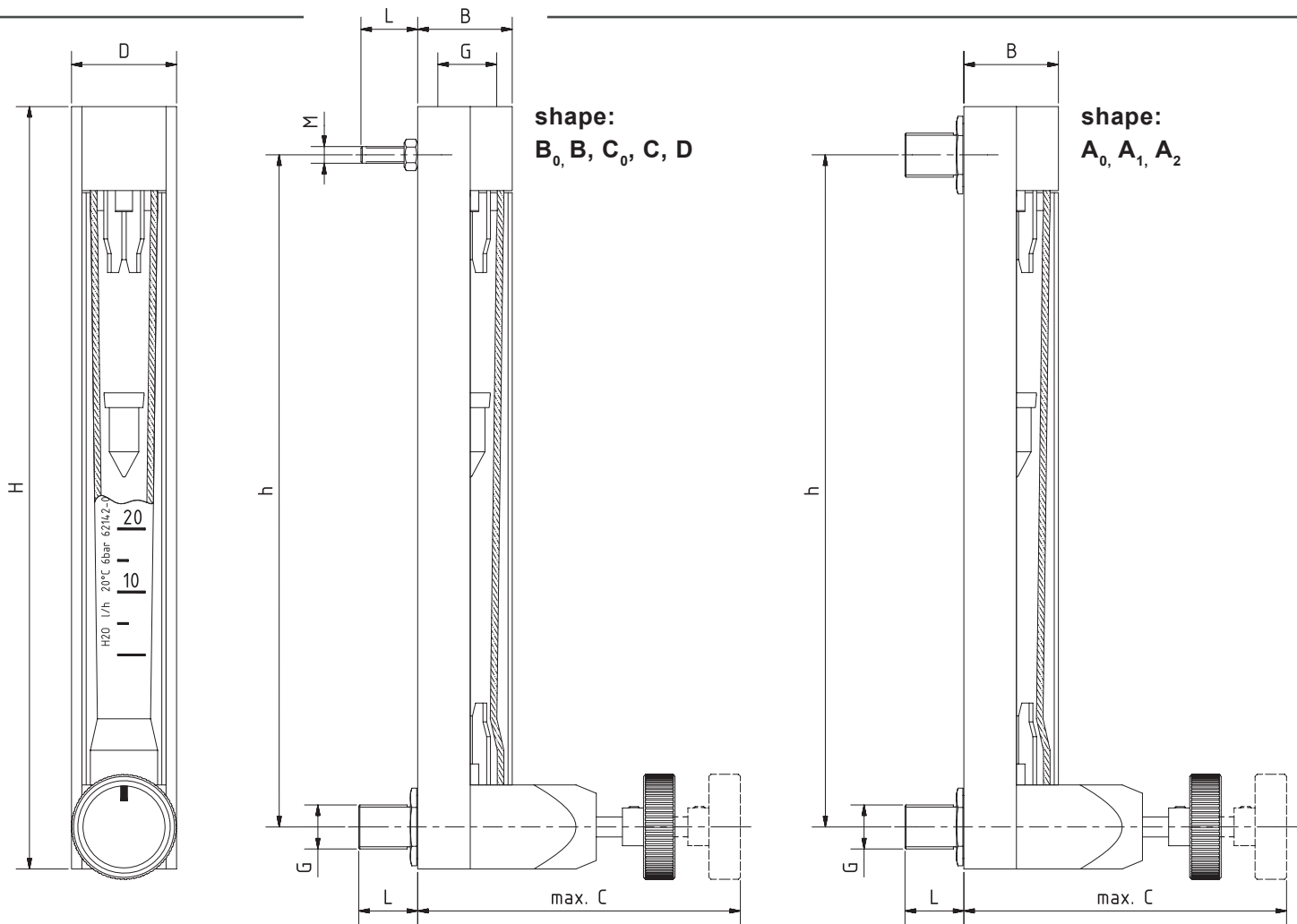

shape:
B₀, B, C₀, C, D

shape:
A₀, A₁, A₂

Measuring range

	measuring range air at STP ¹⁾		measuring range l/h H ₂ O	
SGK-1	0,3 - 3	l/h	0,1 - 1	l/h
	0,25 - 2,5	m ³ /h	15 - 150	l/h
SGK-2	6 - 60	l/h	0,5 - 5	l/h
	0,58 - 5,8	m ³ /h	20 - 200	l/h
SGK-3	0,15 - 1,5	m ³ /h	12 - 120	l/h
	1,6 - 16	m ³ /h	0,12 - 1,2	m ³ /h

measuring ranges for other substances and operating conditions on request
¹⁾ at STP: at standard conditions (0 °C and 1013 mbar abs.)

Limit value switches RC

Up to a flow rate of 30 l/h H₂O or 650 l/h air at STP, the RC inductive switches are available for monitoring limit values. They should be operated together with isolation switching amplifier KFA6-SR2-Ex1W. Please refer to our KFA6-SR2-Ex1W data sheet.

Reed switches of the MSK series are available for flow rates above these values.

Limit value switches MSK1/MSK12/MSKW

In order to realize a local display with a monitoring function the flowmeter can be equipped with limit value switches. The limit value switch consists of a connector housing and a bistable reed switch. A magnet integrated in the float switches this reed switch. The limit value switch is guided in a guide slot on the back of the protective tube and can be adjusted throughout the entire measuring range. In case of inductive or capacitive load applications, e.g. caused by contactors or solenoid valves, uncontrolled current and voltage peaks may occur. In dependence on their geometry such peaks also occur in lines if they exceed a certain length. It is therefore recommended to use an additionally available arc suppression relay "MSR". This increases the switching capacity and avoids the appearance of inductive and capacitive peaks. It thereby ensures a long lifetime of the contact.



SGK 1 - 3

Short-tube VA flow meters

SGK-2-EM

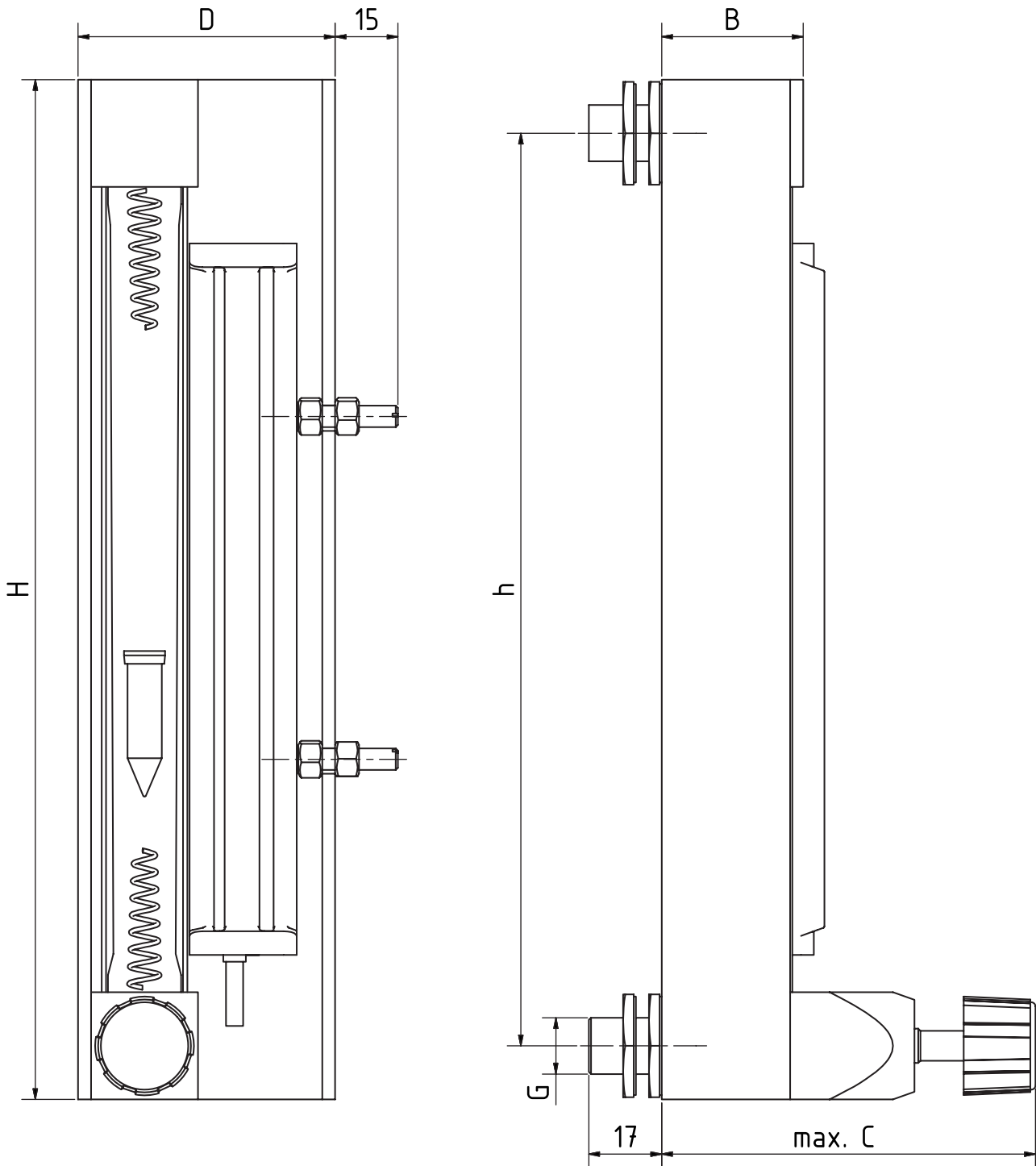

Technical data of the limit value switches

Design	MSK1	MSK12
Switching voltage	50 V AC/75 V DC	50 V AC/75 V DC
Switching current	0,5 A	0,5 A
Switching capacity	10 W/VA	10 W/VA
Dielectric strength	230 V AC/400 V DC	230 V AC/400 V DC
Temperature range ¹⁾	-20 ... +90 °C	-20 ... +90 °C
Switching function	normally closed	normally open
Connection		

Design	MSKW
Switching voltage	50 V AC/75 V DC
Switching current	0,5 A
Switching capacity	5 W/VA
Dielectric strength	110 V AC/200 V DC
Temperature range ¹⁾	-20 ... +90 °C
Switching function	change over
Connection	

¹⁾ The thermal endurance of the flow meter is crucial.

Design	RC 10-14-N3	RC 15-14-N3
Inner diameter	10 mm	15 mm
Rated voltage	8 V DC	
Current consumption	1 mA/3 mA	
Sweep rate	≤ 10 m/s	
Self-inductance	≤ 120 mH	
Self-capacitance	≤ 90 nF	
Temperature range	-20 ... +70 °C	
Switching function	NAMUR bistable	
Connection		

Linear displacement sensor EM

The linear displacement sensor based on the Hall principle delivers an output signal proportional to the height setting of the flow meter. This signal can be displayed in 4 ... 20 mA or 0 ... 10 V to realise a remote indication. The sensor is connected via the enclosed M12 x 1 plug.

- Compact Design
- High level of reproducibility
- Measuring range indication via LED
- Most helpful for SPS integration
- Realise remote indication

Please notice that the sensor has a blind zone in the range of 3.7 mA to around 4 mA and only performs stable operation from approx. 4 mA.

Technical Data

Measurement range [A...B]	125mm
Repeatability	≤ 0,1 % from measurement range ≤ dependent upon position sensor
Linearity deviation	≤ 1 % v.E.
Temperature drift	≤ ± 0,03 %/K
Ambient temperature ¹⁾	-25 ... +65 °C
Operating voltage	15 ... 30 V DC
Idle current	≤ 15 mA
Output function ²⁾	Four-wire, analogue output
Voltage output → Load resistor	0 ... 10 V ≥ 4,7 kΩ
Current output → Load resistor	4 ... 20 mA ≤ 0,4 kΩ
Sampling rate	200 Hz
Connection	Connector, M12 x 1
Protection class	IP67
Operating voltage display	LED, green
Measurement range display	LED, yellow, position sensor in detection range
Connection diagram	

¹⁾ The thermal endurance of the flow meter is crucial.

²⁾ Two wire on request.



SGK 1 - 3

Short-tube VA flow meters

Low Voltage Directive

Above 50 V AC/75 V DC, electrical components are subjected to the EU Low Voltage Directive (LVD). The user is required to verify their use accordingly.

Proper use

The user is responsible for assessing the suitability of the flow meters for his case of application, for use as prescribed and for material compatibility as regards the fluid product used in his process.

The manufacturer shall not be liable for any damage arising from incorrect or improper use of the devices.

Pressure surges can cause glass breakage and should therefore generally be avoided. The limit values given in the data sheet should be observed.

In all other respects we advise following the installation recommendations specified in Code VDI/VDE 3513, Sheet 3.

The equipment from **Kirchner und Tochter** has been tested in compliance with applicable CE-regulations of the European Community. The respective declaration of conformity is available on request. Subject to change without notice. The current valid version of our documents can be found at www.kt-flow.de

The **Kirchner und Tochter** QM-System is certified in accordance with DIN EN ISO 9001:2015. The quality is systematically adapted to the continuously increasing demands.